

Ductile iron Gate Valve outside screw bronze trim PN16 handwheel operated High Temperature

Main characteristics

- Manufactured in Italy in accordance with EN 1171
- Face-to-face length according to EN 558-1, basic series 14
- Flanged according to EN 1092-2 PN10 with flat face, undrilled, PN16 or other specifications on request
- Outside screw thread clockwise closing, adjustable stuffing box
- Minimal pressure drop
- Hydrostatically tested according to EN 12266-1: Test type P11-P12
- Pressure Equipment Directive 2014/68/UE art. 13 Group 1
- 100% full bore
- Provided with ½" drain plug
- Provided with lubricating nipple on motherscrew

Field of application

- Industrial plants
- Sea water use
- Fuel
- Aggressive fluids
- Tanks
- Shipyard
- Transformer oil cooling system

Corrosion protection

Integrally coated with bicomponent wet epoxy resin high corrosion resistant painting Grey Ral 7011



Ratings (DN40 to DN200)

Working temperature (°C)	-10 to +120	+120 to +150
Max Working pressure (bar)	16	14

Ratings (DN250 to DN300)

Working temperature (°C)	-10 to +120	+120 to +150
Max Working pressure (bar)	10	8

Hydrostatically tested according to EN 12266-1 (bar)

P11 Body test	P12 Seat Test water	P12 Seat test air
24	18	6

Material specification

Nr	Parts	Material	Specification
1	Lock nut	Drawn brass CW614N	EN 12164
2	Handwheel	EN-GJL-150 grey cast iron	EN 1561
3	Motherscrew	Cast brass CB 754-S GM	EN 1982
4	Yoke	EN-GJL-250 grey cast iron	EN 1561
5	Packing gland	EN-GJL-250 grey cast iron	EN 1561
6	Packing	Ptfe	ASTM 4894
7	Gasket	Fasit 205	-
8	Stem	Drawn brass-CW614N	EN 12164
9	Bonnet	EN-GJS-400-15 ductile cast iron	EN 1563
10	Gasket	Fasit 205	-
11	Motherscrew	Cast brass CB 754-S GM	EN 1982
12	Wedge DN 40-DN 100	Cast bronze CuSn5Zn5Pb5-B	EN 1982
12	Wedge DN 125-DN 300	EN-GJS-400-15 ductile cast iron	EN 1563
13	Seat	Cast bronze CuSn5Zn5Pb5-B	EN 1982
14	Body	EN-GJS-400-15 ductile cast iron	EN 1563
15	Nut	Zinc-plated 8.8 carbon steel	ISO 4032
16	Screw	Zinc-plated 8.8 carbon steel	EN ISO 4017
17	Tie rod	Zinc-plated 8.8 carbon steel	-
18	Pin	Stainless steel	AISI 316

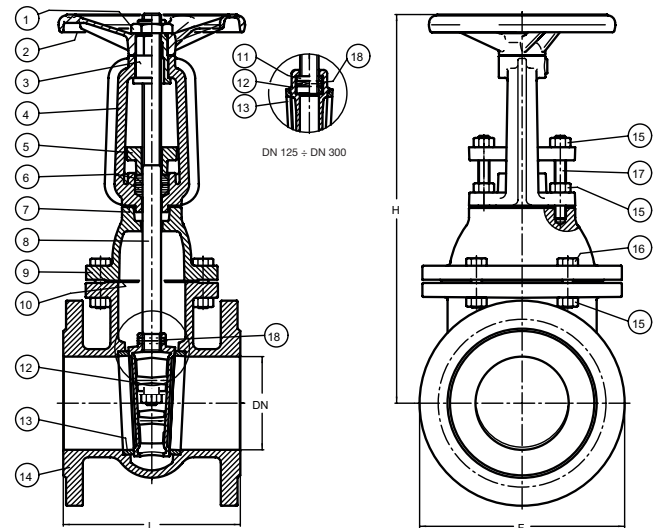

Technical data

DN	40	50	65	80	100	125	150	200	250	300
F mm	150	165	185	200	220	250	285	340	395	445
L mm	140	150	170	180	190	200	210	230	250	270
H mm	265	275	335	355	400	495	585	700	830	960
Weight Kg	10	12	17	22	27	33	43	65	100	142
Handwheel Ø mm	150	150	175	175	200	200	225	225	250	300
Turns open/close nr	10	12.5	16	20	25	25	30	40	50	60
Max torque gate closing Nm	35	35	45	45	50	70	80	80	90	90
Kvs value	107	250	430	790	1.250	1.960	2.790	2.880	4.306	6.380

EN_710 - Edition 07/2024 • Maran Peracini srl assumes no responsibility or liability for typographical errors or omissions and reserves the right to change without notice.

Valvola a saracinesca in ghisa sferoidale a Corpo Piatto vite esterna sede ottone PN16 per Alte Temperature

Principali caratteristiche

- Prodotta in Italia in accordo a EN 1171
- Scartamento secondo EN 558-1, serie 14
- Connessioni flangiate secondo EN 1092-2 PN10 a flangia piana (non forate, PN16 o secondo altre specifiche disponibili su richiesta)
- Asta uscente, chiusura in senso orario, tenuta secondaria sullo stelo regolabile tramite premistoppa
- Minima perdita di carico
- Testata idraulicamente secondo EN 12266-1: Test tipo P11-P12
- Conforme alla Direttiva Attrezzature in Pressione PED 2014/68/UE art. 13 Fluidi di gruppo 1
- 100% passaggio totale

Settori di utilizzo

- Impianti industriali
- Acque di mare
- Carburanti
- Fluidi aggressivi
- Serbatoi
- Cantieri navali
- Circuiti di raffreddamento olio per trasformatori

Protezione dalla corrosione

- Versione Standard: rivestita esternamente con vernice ad alta resistenza alla corrosione con resina oleofenolica ai fosfati di zinco Grigio Ral 7011
- Su richiesta: verniciatura integrale epossidica
- Altre tonalità disponibili



Condizioni di esercizio (DN40 to DN200)

Temperature fluido (°C)	-10 +120	+120 +150
Massima pressione fluido (bar)	16	14

Condizioni di esercizio (DN250 to DN300)

Temperature fluido (°C)	-10 +120	+120 +150
Massima pressione fluido (bar)	10	8

Test idraulico secondo EN 12266-1 (bar)

P11 Corpo	P12 Sedi (acqua)	P12 Sedi (aria)
24	18	6

Specifica materiali

Nr	Parte	Materiale	Norma
1	Controdado	CB 754-S GM ottone fuso	EN 1982
2	Volantino	EN-GJL-150 ghisa grigia	EN 1561
3	Madrevite	CB 754-S GM ottone fuso	EN 1982
4	Cavallotto	EN-GJL-250 ghisa grigia	EN 1561
5	Premistoppa	EN-GJL-250 ghisa grigia	EN 1561
6	Baderna	Ptfe	ASTM 4894
7	Guarnizione	Fasit 205	-
8	Asta	CW614N ottone trafilato	EN 12164
9	Cappello	EN-GJS-400-15 ghisa sferoidale	EN 1563
10	Guarnizione	Fasit 205	-
11	Madrevite	CB 754-S GM ottone fuso	EN 1982
12	Cuneo DN 40-DN 100	CuSn5Zn5Pb5-B bronzo fuso	EN 1982
12	Cuneo DN 125-DN 300	EN-GJS-400-15 ghisa sferoidale	EN 1563
13	Sede	CuSn5Zn5Pb5-B bronzo fuso	EN 1982
14	Corpo	EN-GJS-400-15 ghisa sferoidale	EN 1563
15	Dado	Acciaio Zincato 8.8	ISO 4032
16	Vite	Acciaio Zincato 8.8	EN ISO 4017
17	Tirante	Acciaio Zincato 8.8	-
18	Spina	Acciaio	-

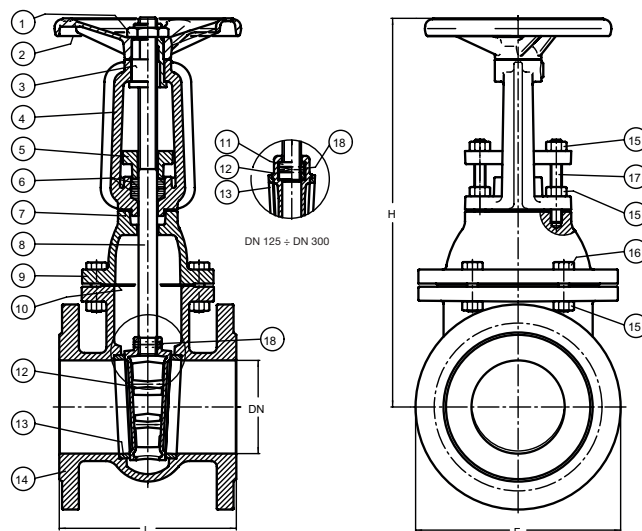

Dati tecnici

DN	40	50	65	80	100	125	150	200	250	300
F mm	150	165	185	200	220	250	285	340	395	445
L mm	140	150	170	180	190	200	210	230	250	270
H mm	265	275	335	355	400	495	585	700	830	960
Peso Kg	10	12	16	20	28	33	43	72	100	134
Volantino Ø mm	150	150	175	175	200	200	225	225	250	300
Giri apertura/chiusura nr	10	12,5	16	20	25	25	30	40	50	60
Momento torcente in chiusura Nm	35	35	45	45	50	70	80	80	90	90
Perdite di carico Kvs	107	250	430	790	1.250	1.960	2.790	2.880	4.306	6.380

IT_710- Edizione 07/2024 • Maran e Peracini srl si riserva il diritto di apportare variazioni senza preavviso.