

Ductile cast iron Gate Valve inside screw soft seating PN16

Main characteristics

- Manufactured in Italy in accordance with EN 1074
- Face-to-face length according to EN 558-1, basic series 14
- Flanged according to EN 1092-2 PN16 with raised face (other specifications on request)
- Inside screw thread clockwise closing, o-ring packing, back seats provided
- Minimal pressure drop
- Hydrostatically tested according to EN 12266-1: Test type P10-P11-P12 Rate A
- Pressure Equipment Directive 2014/68/UE Group 2
- 100% full bore
- EPDM integrally vulcanized wedge

Field of application

- Potable water
- Food industry
- Water treatment
- Fire-fighting
- Irrigation

Corrosion protection

Integrally fusion bonded
Epoxy coated
Blue Ral 5015
250 Micron



Ratings

Working temperature (°C)	-10 to +80
Max Working pressure (bar)	16

Hydrostatically tested according to EN 12266-1 (bar)

P11 Body test	P12 Seat Test water	P12 Seat test air
24	18	6

Material specification

Nr	Parts	Material	Specification
1	Dust proof packing	Pvc	-
2	Bush	CW614N Drawn brass	EN 12164
3	O-ring	Epdm	ISO 4097
4	O-ring	Epdm	ISO 4097
5	Stem	X12Cr13 Stainless Steel	AISI 410
6	Back seat	Ptfe	ASTM 4894
7	Bonnet	EN-GJS-400-15 Ductile cast iron	EN 1563
8	Gasket	Epdm	ISO 4097
9	Wedge	EN-GJS-400-15 Ductile cast iron Epdm integrally Vulcanized	EN 1563
10	Motherscrew	CB 754-S GM Cast brass	EN 1982
11	Body	EN-GJS-400-15 Ductile cast iron	EN 1563
12	Screw	Zinc-plated 8.8 carbon steel	EN ISO 4762
13	Screw tap	Hot Glue	-

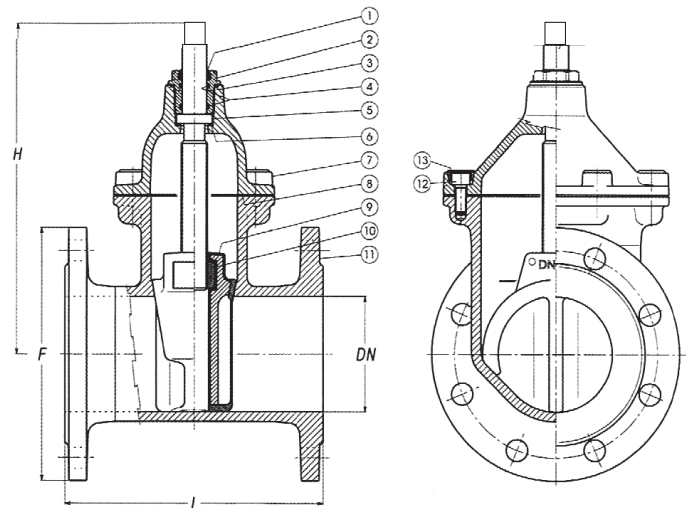

Technical data

DN	40	50	65	80	100	125	150	200	250	300
F mm	150	165	185	200	220	250	285	340	405	460
L mm	140	150	170	180	190	200	210	230	250	270
H mm	191	213	236	265	298	344	388	480	587	664
Weight Kg	9	10	13	16	21	27	34	53	83	109
Turns open/close nr	10	12.5	16	16	20	25	30	33	41	50
Max torque gate closing Nm	35	35	45	50	60	60	80	90	100	120
Kvs value	107	250	430	790	1.250	1.960	2.790	2.880	4.306	6.380

EN_420s - Edition 07/2024 • Maran Peracini srl assumes no responsibility or liability for typographical errors or omissions and reserves the right to change without notice.

Valvola a saracinesca in ghisa sferoidale a corpo piatto vite interna a cuneo gommato PN16

Principali caratteristiche

- Prodotta in Italia in accordo a EN 1074
- Scartamento secondo EN 558-1, serie 14
- Connessioni flangiate secondo EN 1092-2 PN16 con risalto (secondo altre specifiche disponibili su richiesta)
- Stelo interno, chiusura in senso orario, tenuta secondaria sullo stelo con O-ring, provvista di controtenuta
- Minima perdita di carico
- Testata idraulicamente secondo EN 12266-1: Test tipo P11-P12 Rate A
- Conforme alla Direttiva Attrezzature in Pressione PED 2014/68/UE art. 13 Fluidi di gruppo 2
- 100% passaggio totale
- Cuneo rivestito integralmente in EPDM

Settori di utilizzo

- Acqua potabile
- Industria alimentare
- Acque reflue
- Impianti trattamento acque
- Serbatoi
- Alimentazione sistemi antincendio Sprinkler
- Irrigazione

Protezione dalla corrosione

Rivestita integralmente con verniciatura epossidica Ral 5015 spessore 250 Micron



Condizioni di esercizio

Temperature fluido (°C)	-10 to +80
Massima pressione fluido (bar)	16

Test idraulico secondo EN 12266-1 (bar)

P11 Corpo	P12 Sedi (acqua)	P12 Sedi (aria)
24	18	6

Specifica materiali

Nr	Parte	Materiale	Norma
1	Parapolvere	Pvc	-
2	Boccola	CW614N Ottone trafilato	EN 12164
3	O-ring	Epdm	ISO 4097
4	O-ring	Epdm	ISO 4097
5	Asta	X12Cr13 Acciaio inossidabile	AISI 410
6	Contro tenuta	Ptfe	ASTM 4894
7	Cappello	EN-GJS-400-15 Ghisa sferoidale	EN 1563
8	Guarnizione	Epdm	ISO 4097
9	Cuneo	EN-GJS-400-15 Ghisa sferoidale Vulcanizzata integralmente Epdm	EN 1563
10	Madrevite	CB 754-S GM Ottone fuso	EN 1982
11	Corpo	EN-GJS-400-15 Ghisa sferoidale	EN 1563
12	Vite	Acciaio Zincato 8.8	EN ISO 4762
13	Coprivite	Adesivo termofusibile	-

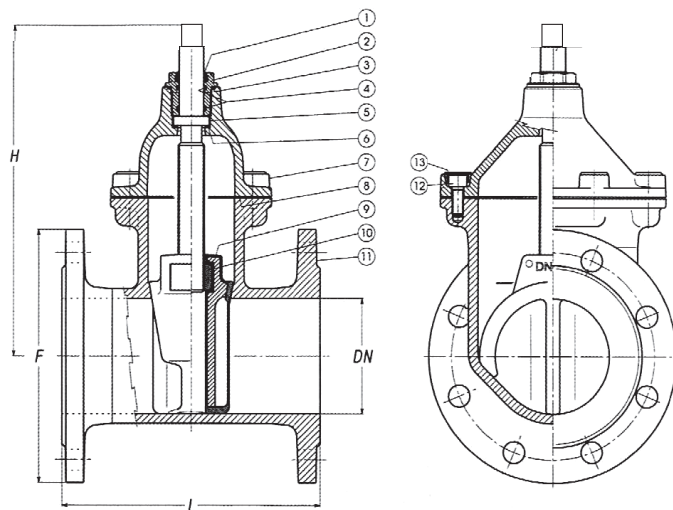

Dati tecnici

DN	40	50	65	80	100	125	150	200	250	300
F mm	150	165	185	200	220	250	285	340	405	460
L mm	140	150	170	180	190	200	210	230	250	270
H mm	191	213	236	265	298	344	388	480	587	664
Peso Kg	9	10	13	16	21	27	34	53	83	109
Giri apertura/chiusura nr	10	12.5	16	16	20	25	30	33	41	50
Momento torcente in chiusura Nm	35	35	45	50	60	60	80	90	100	120
Perdite di carico Kvs	107	250	430	790	1.250	1.960	2.790	2.880	4.306	6.380