

Cast iron Gate Valve inside screw bronze trim PN16 BS 5150/ANSI Class 125 with consol flange ISO 5210 F10

Main characteristics

- Manufactured in Italy in accordance with BS 5150
- Face-to-face length according to EN 558-1, basic series 3
- Flanged according to ANSI B16.1 with flat face (EN 1092-2 PN 16 available)
- Inside screw thread clockwise closing, O.ring packing maintenance free
- Minimal pressure drop
- Hydrostatically tested according to EN 12266-1: Test type P11-P12
- Pressure Equipment Directive 2014/68/UE art. 13 Group 1
- 100% full bore

Field of application

- Industrial plants
- Sewage Water
- Sea Water
- Water treatment
- Air-conditioning systems (HVAC)
- Central heating and cooling circuits
- Aggressive fluids
- Tanks
- Shipyard

Corrosion protection

- Standard version: externally coated with Phenolic-oil resin with zinc-phosphate high corrosion resistance painting Grey Ral 7011
- On request: integrally epoxy coated
- Customized color available



Ratings

Working temperature (°C)	-10 to +120	+120 to +150
Max Working pressure (bar)	16	14

Hydrostatically tested according to EN 12266-1 (bar)

P11 Body test	P12 Seat Test water	P12 Seat test air
24	18	6

Material specification

Nr	Parts	Material	Specification
1	Consol flange	Carbon Steel A105	ISO 5210 F10
2	O-ring	DF801 FKM 80SH	-
3	Gasket	Fasit 205	-
4	Stem	X12Cr13 Stainless Steel	AISI 410
5	Bonnet	EN-GJL-250 grey cast iron	EN 1561
6	Gasket	Fasit 205	-
7	Motherscrew	CB 754-S GM Cast brass	EN 1982
8	Wedge DN 40-DN 65	CuSn5Zn5Pb5-B Cast bronze	EN 1982
8	Wedge DN 80-DN 300	EN-GJL-250 grey cast iron	EN 1561
9	Seats	CuSn5Zn5Pb5-B Cast bronze	EN 1982
10	Body	EN-GJL-250 grey cast iron	EN 1561
11	Nut	Zinc-plated 8.8 carbon steel	ISO 4032
12	Screw	Zinc-plated 8.8 carbon steel	EN ISO 4017

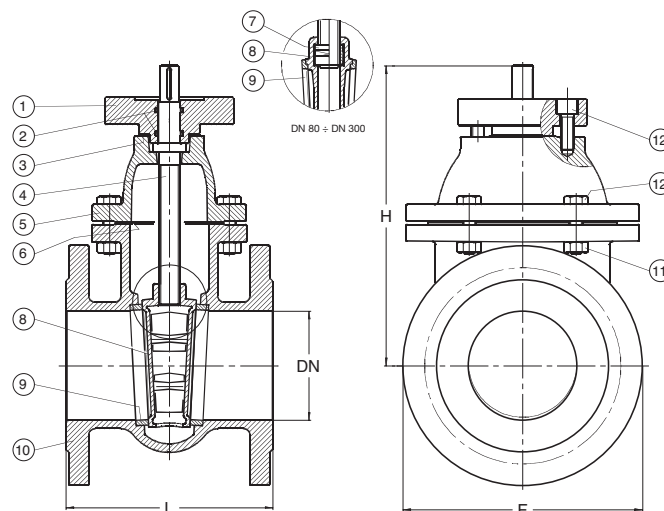

Technical data

DN	50	65	80	100	125	150	200	250	300
F mm	165	185	200	229	250	285	340	405	483
L mm	178	190	203	229	254	267	292	330	356
H mm	245	290	315	355	415	460	545	635	725
Weight Kg	12	16	23	31	42	55	88	134	180
Turns open/close nr	12,5	16	20	25	25	30	40	42	50
Max torque gate closing Nm	30	35	35	40	45	45	60	90	90
Kvs value	250	430	790	1.250	1.960	2.790	2.880	4.306	6.380

EN_235bza - Edition 07/2024 • Maran e Peracini srl assumes no responsibility or liability for typographical errors or omissions and reserves the right to change without notice.

Valvola a saracinesca in ghisa grigia a Corpo Ovale vite interna sede bronzo PN16 per Alte Temperature BS5150/ANSI Class 125 con modulo di accoppiamento ISO 5210 F10

Principali caratteristiche

- Prodotta in Italia in accordo a BS 5150
- Scartamento secondo EN 558-1, serie 3
- Connessioni flangiate secondo ANSI B16.1a flangia piana (EN 1092-2, PN10 o secondo altre specifiche disponibili su richiesta)
- Stelo interno, chiusura in senso orario, tenuta secondaria sullo stelo tramite O-ring
- Minima perdita di carico
- Testata idraulicamente secondo EN 12266-1: Test tipo P11-P12
- Conforme alla Direttiva Attrezzature in Pressione PED 2014/68/UE art. 13 Fluidi di gruppo 1
- 100% passaggio totale

Settori di utilizzo

- Impianti industriali
- Acqua di mare
- Acque reflue
- Impianti trattamento acque
- Sistemi di condizionamento aria (HVAC)
- Centrali termiche e circuiti di raffreddamento
- Fluidi aggressivi
- Serbatoi
- Cantieri navali

Protezione dalla corrosione

- Versione Standard: rivestita esternamente con vernice ad alta resistenza alla corrosione con resina oleofenolica ai fosfati di zinco Grigio Ral 7011
- Su richiesta: verniciatura integrale epossidica
- Altre tonalità disponibili



Condizioni di esercizio

Temperature fluido (°C)	-10 to +120	+120 to +150
Massima pressione fluido (bar)	16	14

Test idraulico secondo EN 12266-1 (bar)

P11 Corpo	P12 Sedi (acqua)	P12 Sedi (aria)
24	18	6

Specifica materiali

Nr	Parte	Materiale	Norma
1	Consol flange ISO 5210	Acciaio al carbonio	A105
2	O-ring	DF801 FKM 80SH	-
3	Guarnizione	Fastit 205	-
4	Asta	X12Cr13 acciaio inossidabile	AISI 410
5	Cappello	EN-GJL-250 ghisa grigia	EN 1561
6	Guarnizione	Fastit 205	-
7	Madrevite	CB 754-S GM ottone fuso	EN 1982
8	Cuneo DN 40-DN 65	CuSn5Zn5Pb5-B bronzo fuso	EN 1982
8	Cuneo DN 80-DN 300	EN-GJL-250 ghisa grigia	EN 1561
9	Sedi	CuSn5Zn5Pb5-B bronzo fuso	EN 1982
10	Corpo	EN-GJL-250 ghisa grigia	EN 1561
11	Dado	Acciaio zincato 8.8	ISO 4032
12	Vite	Acciaio zincato 8.8	EN ISO 4017

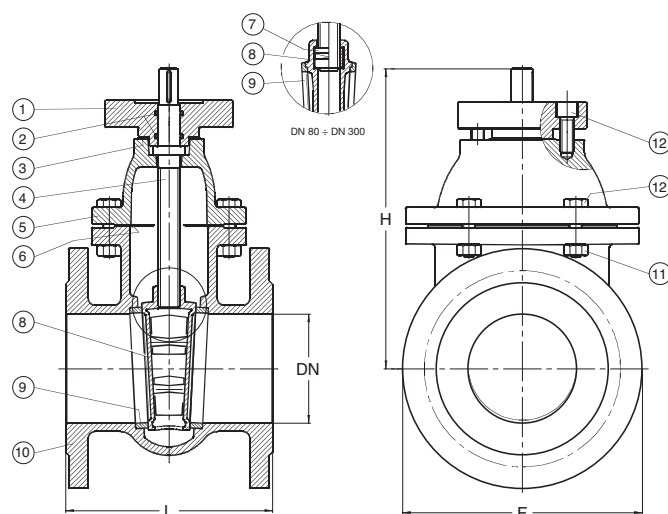

Dati tecnici

DN	50	65	80	100	125	150	200	250	300
F mm	165	185	200	229	250	285	340	405	483
L mm	178	190	203	229	254	267	292	330	356
H mm	245	290	315	355	415	460	545	635	725
Peso Kg	12	16	23	31	42	55	88	134	180
Giri apertura/chiusura nr	12,5	16	20	25	25	30	40	42	50
Momento torcente in chiusura Nm	30	35	35	40	45	45	60	90	90
Perdite di carico Kvs	250	430	790	1.250	1.960	2.790	2.880	4.306	6.380

IT_235bza - Edizione 07/2024 • Maran e Peracini srl si riserva il diritto di apportare variazioni senza preavviso.