

## Cast iron Gate Valve bronze trim PN10 Quick Closing High Temperature

### Main characteristics

- Manufactured in Italy in accordance with EN 1171
- Face-to-face length according to EN 558-1, basic series 14
- Flanged according to EN 1092-2 PN10 with raised face, undrilled, PN16 or other specifications on request)
- Inside screw quick closing, adjustable stuffing box
- Minimal pressure drop
- Hydrostatically tested according to EN 12266-1: Test type P11-P12
- Pressure Equipment Directive 2014/68/UE art. 13 Group 2
- 100% full bore

### Field of application

- Industrial plants
- Sea water
- Fuel
- Shipyard
- Non-aggressive fluids
- Tanks

### Corrosion protection

Externally coated with Phenolic-oil resin with zinc-phosphate high corrosion resistance painting Grey Ral 7011



### Ratings

Working temperature (°C)	-10 to +120	+120 to +150
Max Working pressure (bar)	10	8

### Hydrostatically tested according to EN 12266-1 (bar)

P11 Body test	P12 Seat Test water	P12 Seat test air
15	11	6

### Material specification

Nr	Parts	Material	Specification
1	Fork	CB 754-S GM cast brass	EN 1982
2	Packing gland	EN-GJL-250 grey cast iron	EN 1561
3	Packing	Ptfe	ASTM 4894
4	Stuffing box	EN-GJL-250 grey cast iron	EN 1561
5	Gasket	Fasit 205	-
6	Stem	CW614N Drawn brass	EN 12164
7	Bonnet	EN-GJL-250 grey cast iron	EN 1561
8	Gasket	Fasit 205	-
9	Motherscrew	CB 754-S GM Cast brass	EN 1982
10	Wedge DN 40-DN 100	CuSn5Zn5Pb5-B Cast bronze	EN 1982
10	Wedge DN 125-DN 300	EN-GJL-250 grey cast iron	EN 1561
11	Seats	CuSn5Zn5Pb5-B Cast bronze	EN 1982
12	Body	EN-GJL-250 grey cast iron	EN 1561
13	Nut	Zinc-plated 8.8 carbon steel	ISO 4032
14	Screw	Zinc-plated 8.8 carbon steel	EN ISO 4017
15	Tie rod	Zinc-plated 8.8 carbon steel	-
16	Lever	Carbon Steel	A105
17	Pin	Carbon Steel	-

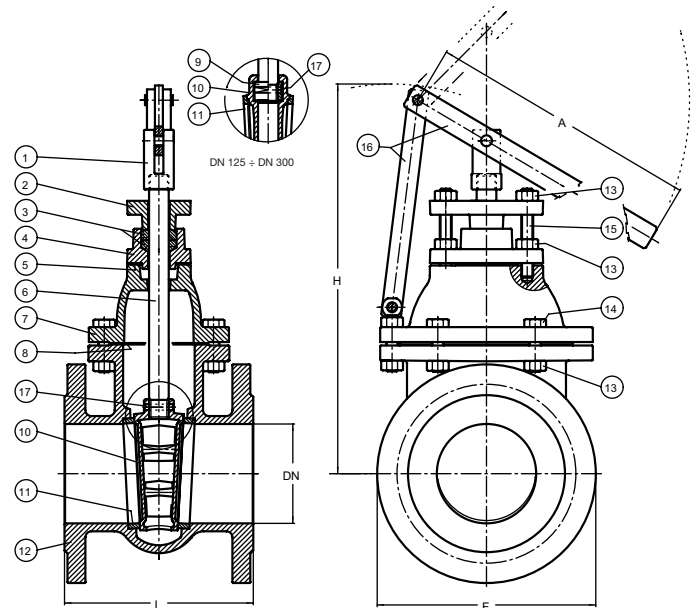

### Technical data

DN	40	50	65	80	100	125	150	200	250	300
F mm	150	165	185	200	220	250	285	340	395	445
L mm	140	150	170	180	190	200	210	230	250	270
H mm	265	280	357	365	390	478	545	660	770	895
Weight Kg	10	12	16	18	23	32	42	68	96	130
A mm	283	283	341	341	373	396	433	433	676	685
Kvs value	107	250	430	790	1.250	1.960	2.790	2.880	4.306	6.380

EN\_165bz - Edition 07/2024 • Maran Peracini srl assumes no responsibility or liability for typographical errors or omissions and reserves the right to change without notice.

## Valvola a saracinesca in ghisa grigia a Corpo Piatto vite interna sede bronzo PN10 chiusura rapida per Alte Temperature

### Principali caratteristiche

- Prodotta in Italia in accordo a EN 1171
- Scartamento secondo EN 558-1, serie 14
- Connessioni flangiate secondo EN 1092-2 PN10 con risalto (non forate, PN16 o secondo altre specifiche disponibili su richiesta)
- Comando a leva, tenuta secondaria sullo stelo regolabile tramite premistoppa
- Minima perdita di carico
- Testata idraulicamente secondo EN 12266-1: Test tipo P11-P12
- Conforme alla Direttiva Attrezzature in Pressione PED 2014/68/UE art. 13 Fluidi di gruppo 2
- 100% passaggio totale

### Settori di utilizzo

- Impianti industriali
- Acque di mare
- Carburanti
- Fluidi non aggressivi
- Serbatoi
- Cantieri navali

### Protezione dalla corrosione

- Versione Standard: rivestita esternamente con vernice ad alta resistenza alla corrosione con resina oleofenolica ai fosfati di zinco Grigio Ral 7011
- Su richiesta: verniciatura integrale epossidica
- Altre tonalità disponibili



### Condizioni di esercizio

Temperature fluido (°C)	-10 to +120	+120 to +150
Massima pressione fluido (bar)	10	8

### Test idraulico secondo EN 12266-1 (bar)

P11 Corpo	P12 Sedi (acqua)	P12 Sedi (aria)
15	11	6

### Specifica materiali

Nr	Parte	Materiale	Norma
1	Forcella	CB 754-S GM ottone fuso	EN 1982
2	Premistoppa	EN-GJL-250 ghisa grigia	EN 1561
3	Baderma	Ptfe	ASTM 4894
4	Portastoppa	EN-GJL-250 ghisa grigia	EN 1561
5	Guarnizione	Fasit 205	-
6	Asta	CW614N ottone trafilato	EN 12164
7	Cappello	EN-GJL-250 ghisa grigia	EN 1561
8	Guarnizione	Fasit 205	-
9	Madrevite	CB 754-S GM ottone fuso	EN 1982
10	Cuneo DN 40-DN 100	CuSn5Zn5Pb5-B bronzo fuso	EN 1982
10	Cuneo DN 125-DN 300	EN-GJL-250 ghisa grigia	EN 1561
11	Sedi	CuSn5Zn5Pb5-B bronzo fuso	EN 1982
12	Corpo	EN-GJL-250 ghisa grigia	EN 1561
13	Dado	Acciaio zincato 8.8	ISO 4032
14	Vite	Acciaio zincato 8.8	EN ISO 4017
15	Tirante	Acciaio zincato 8.8	-
16	Leva	Acciaio al carbonio	A105
17	Spina	Acciaio al carbonio	A105

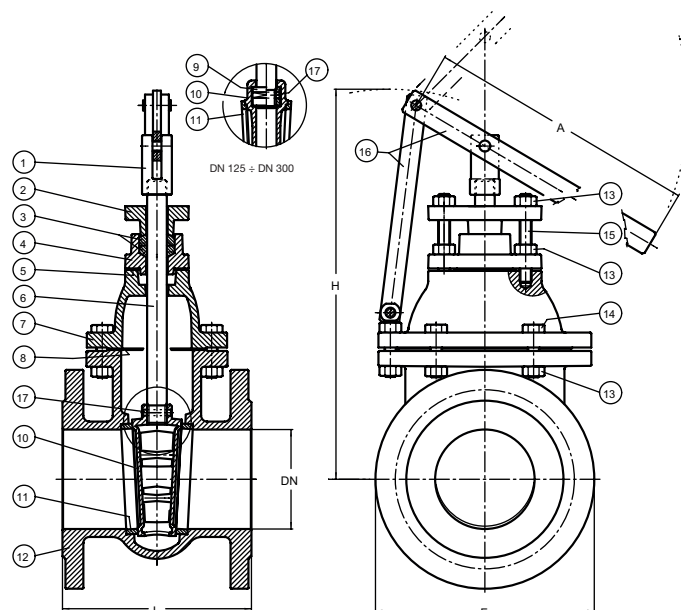

### Dati tecnici

DN	40	50	65	80	100	125	150	200	250	300
F mm	150	165	185	200	220	250	285	340	395	445
L mm	140	150	170	180	190	200	210	230	250	270
H mm	265	280	357	365	390	478	545	660	770	895
Peso Kg	10	12	16	18	23	32	42	66	96	130
A mm	283	283	341	341	373	396	433	433	676	685
Perdite di carico Kvs	107	250	430	790	1.250	1.960	2.790	2.880	4.306	6.380