

## Cast iron Gate Valve outside screw AISI 304L stainless steel trim PN16 High Temperature with consol-flange ISO5210 F10

### Main characteristics

- Manufactured in Italy in accordance with EN 1171
- Face-to-face length according to EN 558-1, basic series 14
- Flanged according to EN 1092-2 PN10 with raised face, undrilled, PN16 or other specifications on request
- Outside screw thread clockwise closing, adjustable stuffing box
- Minimal pressure drop
- Hydrostatically tested according to EN 12266-1: Test type P11-P12
- Pressure Equipment Directive 2014/68/UE Group 1
- 100% full bore

### Field of application

- Industrial plants
- Sewage Water
- Water treatment
- Transformer oil: cooling circuits
- Aggressive fluids
- Tanks
- Fire sprinkler systems

### Corrosion protection

- Standard version: externally coated with Phenolic-oil resin with zinc-phosphate high corrosion resistance painting Grey Ral 7011
- On request: integrally epoxy coated
- Customized color available



### Ratings

Working temperature (°C)	-10 to +120	+120 to +150
Max Working pressure (bar)	16	14

### Hydrostatically tested according to EN 12266-1 (bar)

P11 Body test	P12 Seat Test water	P12 Seat test air
24	18	6

### Material specification

Nr	Parts	Material	Specification
1	Consol-flange ISO5210	Carbon steel	A 105
2	Yoke	EN-GJL-250 grey cast iron	EN 1561
3	Packing gland	EN-GJL-250 grey cast iron	EN 1561
4	Packing	Ptfe	ASTM 4894
5	Gasket	Fasit 205	-
6	Stem	X12Cr13 Stainless Steel	AISI 410
7	Bonnet	EN-GJL-250 grey cast iron	EN 1561
8	Gasket	Fasit 205	-
9	Motherscrew	Carbon steel	A 105
10	Wedge DN 40-DN 100	Carbon steel + AISI 304 L	A 105 + AISI 304 L
10	Wedge DN 125-DN 300	EN-GJL-250 grey cast iron	EN 1561
11	Seat	Stainless steel	AISI 304 L
12	Body	EN-GJL-250 grey cast iron	EN 1561
13	Nut	Zinc-plated 8.8 carbon steel	ISO 4032
14	Screw	Zinc-plated 8.8 carbon steel	EN ISO 4017
15	Tie rod	Zinc-plated 8.8 carbon steel	-
16	Pin	Stainless steel	AISI 316

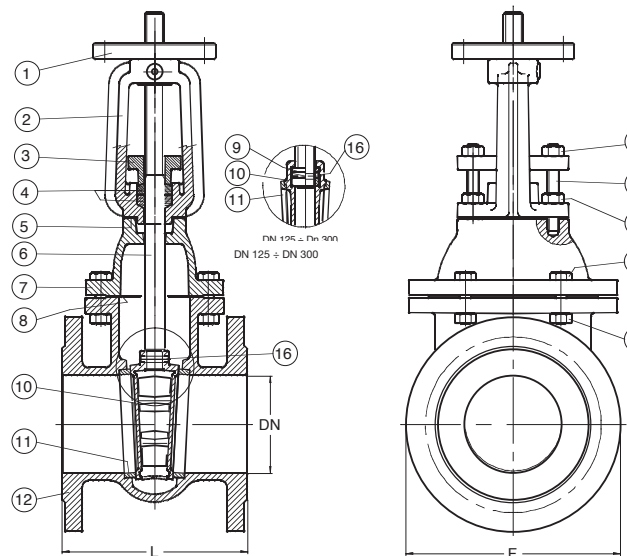

### Technical data

DN	40	50	65	80	100	125	150	200	250	300
F mm	150	165	185	200	220	250	285	340	405	460
L mm	140	150	170	180	190	200	210	230	250	270
H mm	265	275	335	355	400	495	585	700	635	725
Weight Kg	11	13	18	24	30	37	47	72	91	124
Turns open/close nr	10	12,5	16	20	25	25	30	40	50	60
Max torque gate closing Nm	35	35	45	45	50	70	80	80	90	90
Kvs value	107	250	430	790	1.250	1.960	2.790	2.880	4.306	6.380

EN\_130na - Edition 07/2024 • Maran Peracini srl assumes no responsibility or liability for typographical errors or omissions and reserves the right to change without notice.

## Valvola a saracinesca in ghisa grigia a Corpo Piatto vite esterna sede inox AISI 304L PN16 per Alte Temperature con modulo di accoppiamento ISO 5210 F10

### Principali caratteristiche

- Prodotta in Italia in accordo a EN 1171
- Scartamento secondo EN 558-1, serie 14
- Connessioni flangiate secondo EN 1092-2 PN16 con risalto (non forate, PN10 o secondo altre specifiche disponibili su richiesta)
- Asta uscente, chiusura in senso orario, tenuta secondaria sullo stelo regolabile tramite premistoppa
- Minima perdita di carico
- Testata idraulicamente secondo EN 12266-1: Test tipo P11-P12
- Conforme alla Direttiva Attrezzature in Pressione PED 2014/68/UE art. 13 Fluidi di gruppo 1
- 100% passaggio totale

### Settori di utilizzo

- Impianti industriali
- Acque reflue
- Impianti trattamento acque
- Olio per trasformatori: circuiti
- Fluidi aggressivi
- Serbatoi
- Alimentazione sistemi antincendio Sprinkler

### Protezione dalla corrosione

- Versione Standard: rivestita esternamente con vernice ad alta resistenza alla corrosione con resina oleofenolica ai fosfati di zinco Grigio Ral 7011
- Su richiesta: verniciatura integrale epossidica
- Altre tonalità disponibili



### Condizioni di esercizio

Temperature fluido (°C)	-10 to +120	+120 to +150
Massima pressione fluido (bar)	16	14

### Test idraulico secondo EN 12266-1 (bar)

P11 Corpo	P12 Sedi (acqua)	P12 Sedi (aria)
24	18	6

### Specifica materiali

Nr	Parte	Materiale	Norma
1	Consol-flange ISO5210	Acciaio al carbonio	A 105
2	Cavallo	EN-GJL-250 ghisa grigia	EN 1561
3	Premistoppa	EN-GJL-250 ghisa grigia	EN 1561
4	Baderna	Ptfe	ASTM 4894
5	Guarnizione	Fasit 205	-
6	Asta	X12Cr13 acciaio inossidabile	AISI 410
7	Cappello	EN-GJL-25 ghisa grigia	EN 1561
8	Guarnizione	Fasit 205	-
9	Madrevite	Acciaio al carbonio	A 105
10	Cuneo DN 40-DN 100	Acciaio al carbonio +	
		AISI 304L acciaio inossidabile	A105+AISI 304L
10	Cuneo DN 125-DN 300	EN-GJL-250 ghisa grigia	EN 1561
11	Sedi	Acciaio inossidabile	AISI 304L
12	Corpo	EN-GJL-250 ghisa grigia	EN 1561
13	Dado	Acciaio zincato 8.8	ISO 4032
14	Vite	Acciaio zincato 8.8	EN ISO 4017
15	Tirante	Acciaio zincato 8.8	-
16	Spina	Acciaio inossidabile	AISI 316

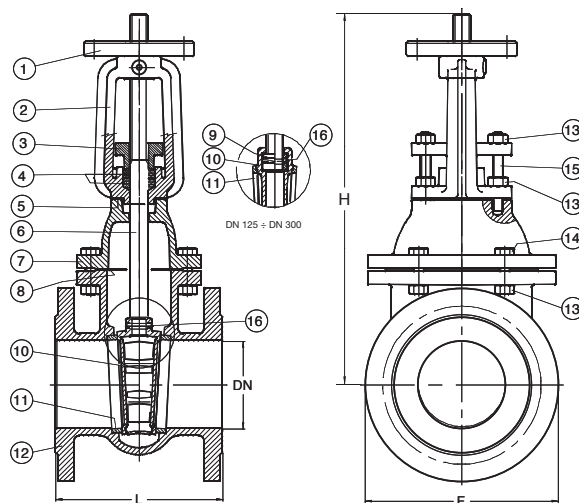

### Dati tecnici

DN	40	50	65	80	100	125	150	200	250	300
F mm	150	165	185	200	220	250	285	340	405	460
L mm	140	150	170	180	190	200	210	230	250	270
H mm	265	275	335	355	400	495	585	700	635	725
Peso Kg	11	13	18	24	30	37	47	72	91	124
Giri apertura/chiusura nr	10	12,5	16	20	25	25	30	40	50	60
Momento torcente in chiusura Nm	35	35	45	45	50	70	80	80	90	90
Perdite di carico Kvs	107	250	430	790	1.250	1.960	2.790	2.880	4.306	6.380

IT\_130na - Edizione 07/2024 • Maran e Peracini srl si riserva il diritto di apportare variazioni senza preavviso.