

Cast iron Gate Valve inside screw bronze trim PN16 High Temperature with consol-flange ISO5210 F10

Main characteristics

- Manufactured in Italy in accordance with EN 1171
- Face-to-face length according to EN 558-1, basic series 14
- Flanged according to EN 1092-2 PN10 with raised face, undrilled, PN16 or other specifications on request
- Inside screw thread clockwise closing
- Minimal pressure drop
- Hydrostatically tested according to EN 12266-1: Test type P11-P12
- Pressure Equipment Directive 2014/68/UE Group 1
- 100% full bore

Field of application

- Industrial plants
- Sea water use
- Fuel
- Aggressive fluids
- Tanks
- Shipyards

Corrosion protection

- Standard version: externally coated with Phenolic-oil resin with zinc-phosphate high corrosion resistance painting Grey Ral 7011
- On request: integrally epoxy coated
- Customized color available

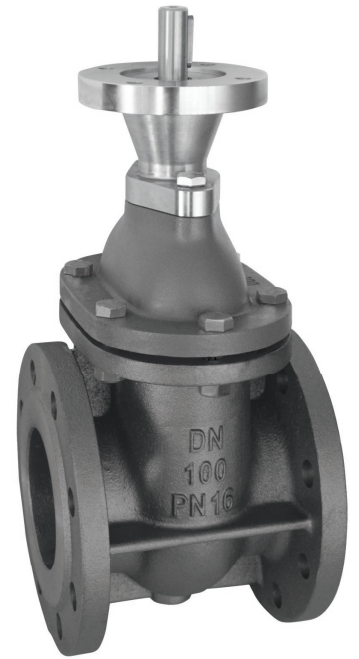

Ratings

Working temperature (°C)	-10 to +120	+120 to +150
Max Working pressure (bar)	16	14

Hydrostatically tested according to EN 12266-1 (bar)

P11 Body test	P12 Seat Test water	P12 Seat test air
24	18	6

Material specification

Nr	Parts	Material	Specification
1	Consol-flange ISO5210	Carbon steel	A 105
2	O-ring	DF801 FKM 80SH	-
3	Gasket	Fasit 205	-
4	Stem	X12Cr13 Stainless Steel	AISI 410
5	Bonnet	EN-GJL-250 grey cast iron	EN 1561
6	Gasket	Fasit 205	-
7	Motherscrew	CB 754-S GM Cast brass	EN 1982
8	Wedge DN 40-DN 100	CuSn5Zn5Pb5-B Cast bronze	EN 1982
8	Wedge DN 125-DN 300	EN-GJL-250 grey cast iron	EN 1561
9	Seats	CuSn5Zn5Pb5-B Cast bronze	EN 1982
10	Body	EN-GJL-250 grey cast iron	EN 1561
11	Motherscrew	CB 754-S GM Cast brass	EN 1982
12	Screw	Zinc-plated 8.8 carbon steel	EN ISO 4017

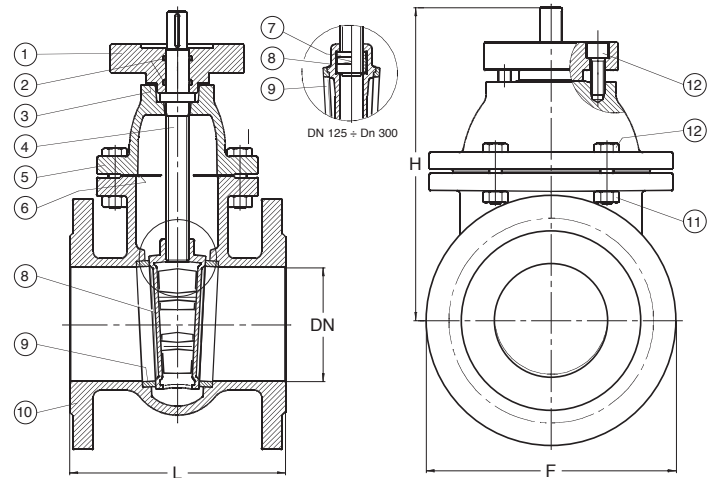

Technical data

DN	40	50	65	80	100	125	150	200	250	300
F mm	150	165	185	200	220	250	285	340	405	460
L mm	140	150	170	180	190	200	210	230	250	270
H mm	185	205	229	255	285	344	385	460	635	725
Weight Kg	11	13	17	20	25	33	43	65	91	124
Turns open/close nr	10	12,5	16	20	25	25	30	40	50	60
Max torque gate closing Nm	35	35	45	45	50	70	80	80	90	90
Kvs value	107	250	430	790	1.250	1.960	2.790	2.880	4.306	6.380

Valvola a saracinesca in ghisa grigia a Corpo Piatto vite interna sede bronzo PN16 per Alte Temperature con modulo di accoppiamento ISO 5210 F10

Principali caratteristiche

- Prodotta in Italia in accordo a EN 1171
- Scartamento secondo EN 558-1, serie 14
- Connessioni flangiate secondo EN 1092-2 PN10 con risalto (non forate, PN16 o secondo altre specifiche disponibili su richiesta)
- Stelo interno, chiusura in senso orario, tenuta secondaria sullo stelo con 2 O-ring
- Minima perdita di carico
- Testata idraulicamente secondo EN 12266-1: Test tipo P11-P12
- Conforme alla Direttiva Attrezzature in Pressione PED 2014/68/UE art. 13 Fluidi di gruppo 1
- 100% passaggio totale

Settori di utilizzo

- Impianti industriali
- Acque di mare
- Carburanti
- Fluidi aggressivi
- Serbatoi
- Cantieri navali

Protezione dalla corrosione

- Versione Standard: rivestita esternamente con vernice ad alta resistenza alla corrosione con resina oleofenolica ai fosfati di zinco Grigio Ral 7011
- Su richiesta: verniciatura integrale epossidica
- Altre tonalità disponibili

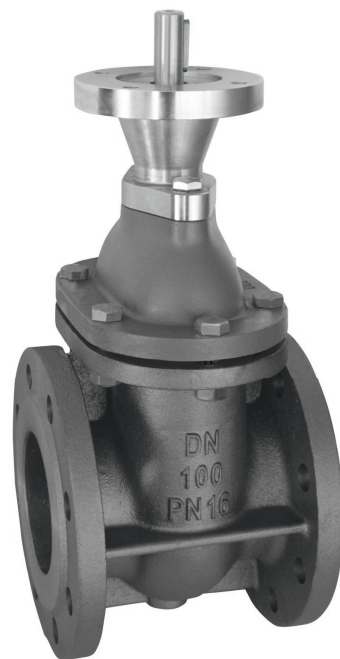

Condizioni di esercizio

Temperature fluido (°C)	-10 to +120	+120 to +150
Massima pressione fluido (bar)	16	14

Test idraulico secondo EN 12266-1 (bar)

P11 Corpo	P12 Sedi (acqua)	P12 Sedi (aria)
24	18	6

Specifica materiali

Nr	Parte	Materiale	Norma
1	Consol-flange ISO5210	Acciaio al carbonio	A 105
2	O-ring	DF801 FKM 80SH	-
3	Guarnizione	Fasit 205	-
4	Asta	X12Cr13 acciaio inossidabile	AISI 410
5	Cappello	EN-GJL-250 ghisa grigia	EN 1561
6	Guarnizione	Fasit 205	-
7	Madrevite	Acciaio al carbonio	A 105
8	Cuneo DN 40-DN 100	CuSn5Zn5Pb5-B bronzo fuso	EN 1982
8	Cuneo DN 125-DN 300	EN-GJL-250 ghisa grigia	EN 1561
9	Sedi	CuSn5Zn5Pb5-B bronzo fuso	EN 1982
10	Corpo	EN-GJL-250 ghisa grigia	EN 1561
11	Dado	Acciaio zincato 8.8	ISO 4032
12	Vite	Acciaio zincato 8.8	EN ISO 4017

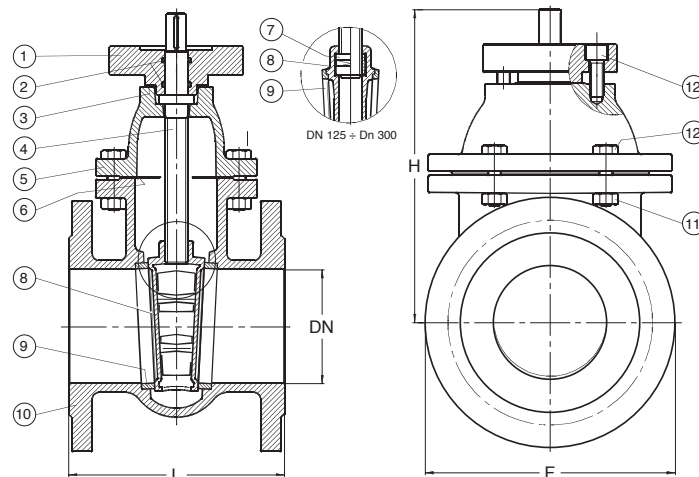

Dati tecnici

DN	40	50	65	80	100	125	150	200	250	300
F mm	150	165	185	200	220	250	285	340	405	460
L mm	140	150	170	180	190	200	210	230	250	270
H mm	185	205	229	255	285	344	385	460	635	725
Peso Kg	10	12	16	20	26	35	45	68	91	124
Giri apertura/chiusura nr	10	12,5	16	20	25	25	30	40	50	60
Momento torcente in chiusura Nm	35	35	45	45	50	70	80	80	90	90
Perdite di carico Kvs	107	250	430	790	1.250	1.960	2.790	2.880	4.306	6.380